



POLARIS Touch Panel 5.7"

Features

- LED technology
- Higher screen resolution
- Touchscreen
- Processor up to 1.6 GHz
- Remote desktop solution
- Presentation of HTML pages
- Direct connection in hazardous areas
- Option of Windows 7®
- Integrated keyboard customisation

Description

The POLARIS Touch Panel 5.7" is an innovative further development of the POLARIS Panel PCs 5.7".

High-resolution displays with LED technology and touchscreen for intuitive as well as comfortable operation are available now in the standard variant.

State-of-the-art LED display technology ensures the optimum contrast even with a large viewing angle.

The proven LX800 offers sufficient computer capacity for presenting HTML pages or functioning as a remote client.

Of course, here too the user can work with the latest "BMS-Graf-pro" Runtime 7 under Windows® XP Embedded, for example for the transmission of projects over the Ethernet, the use of graphics lists or an integrated user administration.

For higher computer capacities there is an option of a highly efficient Intel® Atom™ with 1.6 GHz.

To allow optimum operation, the keyboard layout can be adjusted by software to suit the Windows®, BMS-Graf-pro 7, Siemens WinCC flexible®, RS View® user software.

Allows a high-performance visual display and operation of the processes directly on site.

The front-panel fitting makes mounting easy. On request, the devices are also available as turn-key system solutions in a stainless steel enclosure for wall, floor or ceiling mounting.

An intrinsically safe USB interface is available for a USB Ex i memory stick. Intrinsically safe input devices can be connected also.

Explosion protection

Ex protection type

ATEX Ex II 2G Ex db eb qb [ib op pr] IIC T4
Ex II 2D Ex tb IIIC T120°C IP 6X

Certification

IBExU 05 ATEX 1117 X

IECEX Ex db eb qb [ib] IIC T4
Ex tb IIIC T120°C IP 6X

Certification

IECEX IBE 11.0007 X

Further approvals

INMETRO, GOST-R

Protection class

IP 65 (front)
IP 54 (back)

Technical data

Construction

Front-panel fitting

Display

- 5.7" TFT graphic display
- 262,144 colours
- Resolution VGA 640 x 480 pixels
- Brightness 700 cd/m²
- Visible surface approx. 115 x 86 mm
- Contrast 800:1
- Touchscreen (resistive)

Background lighting

- LED technology
- Service life approx. 50,000 hours (at +25 °C)

Computer capacity

- LX800 processor, 500 MHz
Compact Flash 4 GB
- Intel® Atom™ N270, 1.6 GHz optional
16 GB HD

Operating system

- Windows® XP Embedded (pre-installed)
- Windows® XP Professional (optional)

Keyboard (short-stroke keys)

- alphanumeric key block
- 4 cursor keys
- 6 special keys
- 10 function keys able to be labelled with LEDs

Interfaces (basic version)

- 1 x Ex e Ethernet 100/10BaseT (option of optical fibres)
- 1 x Ex e RS422
- 1 x Ex i USB for Ex i memory stick
- 1 x Ex i PS/2 for intrinsically safe mouse

Dimensions (width x height x depth)

335 mm x 199 mm x approx. 130 mm

Wall cut-out

321 mm x 179 mm + 0.5 mm

Weight

approx. 10 kg



POLARIS COMFORT POLARIS Touch Panel 5.7"

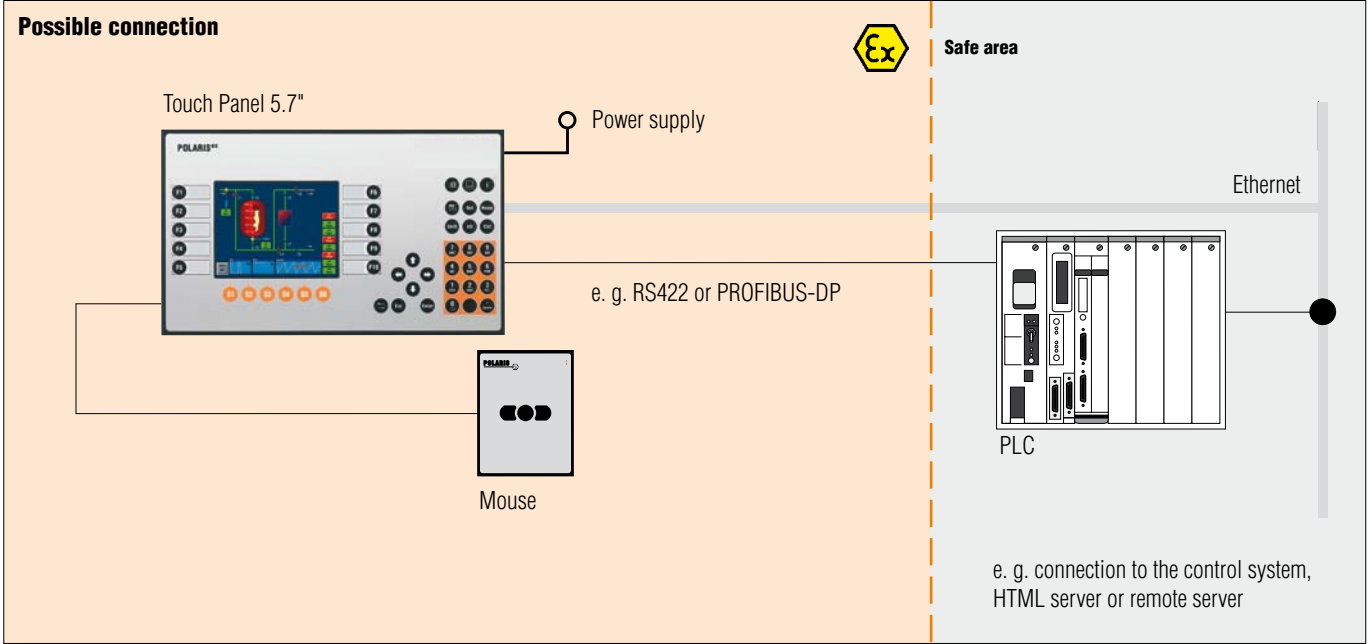

Power supply

DC 24 V ± 10 %

Max. power consumption

$P_{max} < 30 \text{ W}$

Permissible ambient temperatures

Storage -20 °C to +50 °C
 Operation 0 °C to +50 °C

Variant

Operation -20 °C to +50 °C
 on request (without external heating)

Relative air humidity

5 to 95 % non-condensing

Vibration

0.7 G/1 mm; 5 Hz - 500 Hz pulse in all 3 axes

Shock

15 G/11 ms pulse in all 3 axes

Material

Front Polyester foil on anodised aluminium plate (conditionally UV-resistant)
 Back bichromated sheet steel

Selection chart

Version	Interfaces	Code no.
Touch Panel 5.7"	RS422	00
	PROFIBUS-DP	02
	RS232	09
	TTY	11
	PROFIBUS-DP, Ex d-USB	33
	Further Interface combinations on request	XX

➔ **Complete order no. 17-71V1-A0** **/X000**

Please insert correct code.

Technical data subject to change without notice.

You will find the accessories with order details on the accessories pages.